

Low Voltage Stackable Energy Storage Battery

Installation and Operation Manual



www.aforeenergy.com

Afore

Afore New Energy Technology (Shanghai) Co., Ltd.

T +86-21-54326236 F +86-21-54326136 E info@aforeenergy.com

Ad Building 7, No.333 Wanfang Rd, Minhang District, Shanghai, China. 201112

Afore

Afore New Energy Technology (Shanghai) Co., Ltd.



AF5000W-LE Operation Manual

This Manual introduces AF5000W-LE.

AF5000W-LE is a Low-voltage Lithium-iron Phosphate Battery energy storage system. Please read this manual before you install the battery and follow the instruction carefully during the installation process.

Catalogue

1	Technical Specification	1-2
2	Safety Information	
2.1	General Safety	3
2.2	Personal Safety	3-4
2.3	Electrical Safety	4-6
2.4	Transportation Safety	6
3	System Information	
3.1	Product Introduction	7
3.2	Battery Module	7
3.3	Port Definitions	8-10
3.3.1	Connection Area	8
3.3.2	ON/OFF	8
3.3.3	Link Com Port	9
3.3.4	Link Power/Link in/Link out	9
3.3.5	LED Indicator Definition	10
4	Installation	
4.1	Tools	11
4.2	Checking Deliverables	12-14
4.3	Installation	15-22
5	Commissioning Procedure	23
6	Maintenance	24

1. Technical Specification

Power Module Model	Number of battery Modules	Battery System Capacity	Battery Cell Technology	Battery System Voltage	Operating Voltage Range	Dimension (W*D*H)	Net Weight
AF5000W-LE	1	5.12kWh	Li-iron(LFP)	51.2V	45.6-56.2V	600*210*440(mm) 23.62*8.27*17.32(inch)	57.2kg (126.1 lb)
	2	10.24kWh				600*210*740(mm) 23.62*8.27*29.13(inch)	106.9kg (235.67 lb)
	3	15.36kWh				600*210*1040(mm) 23.62*8.27*40.94(inch)	156.6kg (345.24 lb)
	4	20.48kWh				600*210*1340(mm) 23.62*8.27*52.76(inch)	206.3kg (454.81 lb)

AF5000W-LE	Battery Base dimensions (W*D*H)	Battery Cover dimensions (W*D*H)	Battery Base Weight	Battery Cover Weight
	600*210*90 (mm) 23.62*8.27*3.54 (inch)	600*210*50 (mm) 23.62*8.27*1.97 (inch)	5kg (11.02lb)	2.5kg (5.51lb)

Scalability	Installation	Depth of Discharge	Battery System Charge Current (recommendl)	Battery System Charge Current (Max)	Battery System Discharge Current (recommend)	Battery System Discharge Current (Max)	Display	Certificates
Max 15 in parallel	Floor stand	90%	50A	100A	50A	100A	The information of the Battery, such as SOC, battery status	IEC62619 / IEC61000 / IEC62040 / CE / UN38.3
Communication Port	Protection Class	Charging temperature	Discharge temperature	Humidity	Max. operating altitude	Warranty/ Number of cycles	Cooling	
RS232, RS485, CAN	IP65	0°C~50°C (32°F-122°F)	-20°C~55°C (-4°F-122°F)	5%-95%	2000m (6561,68ft.)	10 years/ 6000 times/ 80% DOD	Natural convection	

AF5000W-LE	Battery Cell Capacity	Configuration	Battery Module Dimensions (W*D*H)
	100Ah	1P16S	600*210*300(mm) 23.62*8.27*11.81 (inch)
	Battery module capacity	Battery Module Voltage	Battery Module Weight
	5.12kWh	51.2V	49.7kg (109.57 lb)



2. Safety Information

2.1 General Safety

Please read the user manual carefully and check all the safety instructions on the equipment and in this document.

The "DANGER", "WARNING", and "NOTICE" statements in this document do not cover all the safety instructions. They are only supplements to the safety instructions.

For user safety and utilization efficiency of this manual, a list of symbols is designed to alert people from danger. You must understand and comply with the emphasized information to avoid personal injury and property damage. Relative safety symbols have been listed below.

 Danger	DANGER indicates a hazardous situation which, if not avoided, will result in serious injury and/or fire.
 Warning	WARNING indicates a hazardous situation which, if not avoided, will result in property loss and/or void the warranty.
 NOTICE	NOTICE indicates normal situation which, if not avoided, will result in damage to the battery.

NOTICE

Follow local laws and regulations when installing, operating, or maintaining the equipment. The safety instructions in this document are only the supplements to local laws and regulations.

2.2 Personal Safety

Personal Requirements

People who plan to install or maintain battery equipment must be trained, understand all necessary safety precautions, and are able to correctly perform all operations. Only qualified professionals or trained people are allowed to install, operate, and maintain the equipment.







▲ DANGER

- Keep the batteries away from children and pets.
- Do not touch the energized battery, the temperature of the battery enclosure may increase during operation.
- Do not touch the energized battery terminals.
- Do not stand on, lean on, or sit on the battery.

2.3 Electrical Safety

Symbols on Battery

There are some electrical symbols on battery relate to electrical safety. Please make sure you have fully understood them before installation.

	Electrical danger	Voltage exists when the battery is powered on. Only qualified engineers are allowed to operate.
	Earth connector	Earth connection.
	DC positive and negative connectors	Identify positive and negative connectors of DC power source.
	CE mark	The product meets CE certification.
	WEEE label	Batteries must not be disposed with general waste. It must be appropriately recycled in accordance with local regulations.
	Recycle	Batteries can be recycled, please refer to your local regulations regarding the correct disposal methods.

Electrical Safety

DANGER

- Before installation, ensure that the equipment is intact. Otherwise, electric shock or fire may occur.
- Do not connect or disconnect power cables when battery is power-on. Which may cause electric arcs and sparks moreover fire or personal injury.
- Before connecting a power cable, check the positive or negative connectors are correct.
- Do not connect the battery with different batteries in parallel.
- Do not connect the battery with AC supply directly.
- Do not connect the battery with PV wiring directly.
- Do not connect the batteries in series.
- Do not connect the battery to faulty or unqualified inverter or charger.
- Do not create short circuits with the external connection.
- Make sure the grid is cut off and the battery is powered off before maintenance.
- Make sure the earth cable is connected correctly before operation.

WARNING

- Recharge the battery in every six months if not in use.
- Recharge the battery within 10 days after the battery is fully discharged(SOC=0%).
- Ensure the battery cable is installed correctly.
- When the battery is being installed or repaired, ensure the battery is powered off and and isolated. Using a multimeter check to ensure there is no voltage in the positive and negative terminals.

CAUTION

- Please use appropriately insulated tools for installation and maintenance.
- Please check the LED status indicator when the battery is powered on.

- Please ensure the communication cable is connected correctly between the battery and the inverter.
- Please check for inverter alarms and the SOC reading once communication is established between the inverter and the battery.

Environment Safety

WARNING

- Ensure the battery is installed in a dry and well-ventilated location.
- The installation position must be away from direct sunlight and rain.
- The installation position must be far away from potential sources of fire..
- The installation position must be far away from all sources of water.
- Do not install the equipment in locations that contain flammable gases and/or flammable liquids.
- The operation and service life of the battery depends on the operating temperature. Operate the battery at a temperature equal to or better than the ambient temperature. The recommended operating temperature range is from 0°C to 30°C.

2.4 Transportation Safety

WARNING

- The products have passed UN38.3 certification.
- The products have MSDS documents available.
- The products belong to class 9 dangerous goods.
- **Please protect the packing case from the following situations:**
 - Being dampened by rains, snows, or falling into water.
 - Falling down or mechanical impact.
 - Being upside-down or tilted.

3. System Information

3.1 Product Introduction

AF5000W-LE is a low-voltage battery storage system based on lithium-iron phosphate technology. It is used to primarily store excess power that is generated by an inverter based on PV system.

3.2 Battery Module

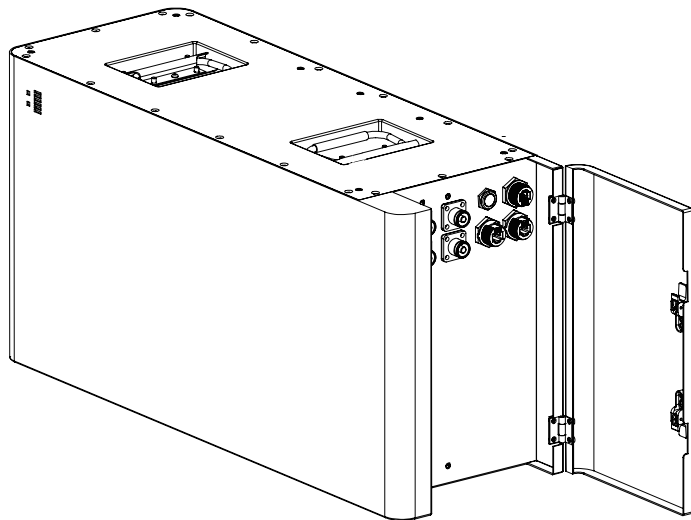

3.3 Port definitions

3.3.1 Connection Area

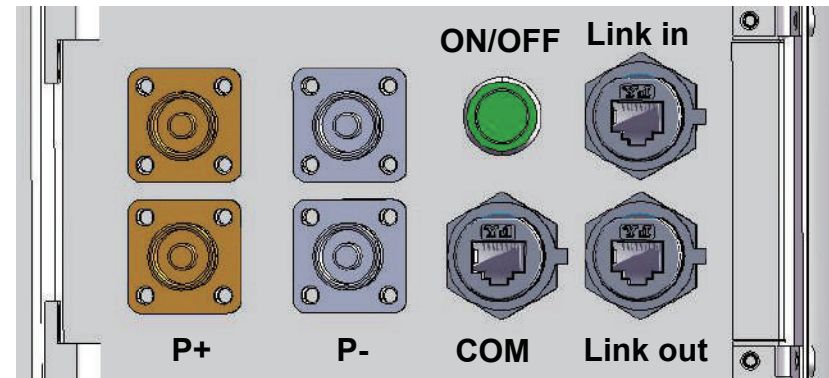

3.3.2 ON/OFF

1. ON

For single Battery Module, long press (more than 3 seconds) ON/OFF button, the Normal LED indicator on the front panel will flash, then the battery will operate normally. L1 to L6 show battery SOC, L7/L8 shows battery status.

For multiple Battery Modules in parallel, long press (more than 3 seconds) ON/OFF button of MASTER battery (which is connected to the inverter), the Normal LED indicator will flash, then the battery system will automatically encode and assign ID to each slave battery and the battery system will operate normally.

Note: For multiple batteries in parallel, only the LED State of Charge indicator of the Master battery will flash to show the SOC level of the whole system, and the LED State of Charge indicators of the slave batteries will turn off, while the Normal&Alarm LED indicators will operate normally.

2 OFF

Press ON/OFF button of the Master PACK (which is connected to the inverter) for more than 3s, the LED indicator on the front panel will flash, and then release the button, the master pack will shut down after all the slave packs shut down (Sleep Mode).

For single Battery Module, long press (more than 3 seconds) ON/OFF button, the LED indicator on the front panel will flash, and then release the button, the battery will shut down.

For the system connected with inverter, there is an air switch between the inverter and battery system, normally the air switch keeps off-state if the system does not work.

3.3.3 Link Communication Port

The Link Communication Port is the interface between the battery packs and the inverter. The inverter retrieves the battery data such as SOC, DOD, charge current via this connection.

RJ45 port supports CAN / RS485 / RS232 communication protocol.

CAN/RS485 communication terminal (RJ45 port) connects to the inverter and follows CAN / RS485 protocol.

RS232 communication terminal (RJ45 port) follows RS232 protocol, for manufacturer or professional engineer to debug or service.

PIN	Definition
Pin 1	RS485-B (to PCS, reserved)
Pin 2	RS485-A (to PCS, reserved)
Pin 3	GND_2
Pin 4	CANH (to PCS)
Pin 5	CANL (to PCS)
Pin 6	RS232_TX
Pin 7	RS232_RX
Pin 8	RS232_GND

3.3.4 Link Power/Link in/Link out

Link Power/Link in/Link out are used for the communication between the battery packs.

The battery pack closed to the inverter is the master pack, others are the slave packs.

3.3.5 LED Indicator Definition

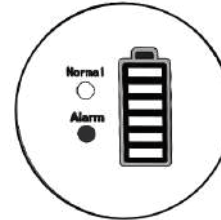

flash 1 - 0.25s on/3.75s off

flash 2 - 0.5s on/ 0.5s off









flash 3 - 0.5s on/ 1.5s off

LED Indicators Definitions

	Normal	Fault	Battery Level Indicator						Descriptions	
			L8	L7	L6	L5	L4	L3		L2
Status	●	●	●	●	●	●	●	●	●	All OFF
Shut down	OFF	OFF	OFF	OFF	OFF	OFF	OFF	OFF	OFF	All OFF
Standby	Flash 1	OFF	According to the battery level						Indicates Standby	
Charging	Normal	Light	OFF	According to the battery level						The highest capacity LED indicator flashes(flash 2),others lighting
	Full Charged	Light	OFF	Light	Light	Light	Light	Light	Light	Turn to standby status when charger off
	Protection	OFF	Light	OFF	OFF	OFF	OFF	OFF	OFF	Stop charging
Discharge	Normal	Flash 3	OFF	According to the battery level						
	UVP	OFF	OFF	OFF	OFF	OFF	OFF	OFF	OFF	Stop charging
	Protection	OFF	Light	OFF	OFF	OFF	OFF	OFF	OFF	Stop discharging
Fault	OFF	Light	OFF	OFF	OFF	OFF	OFF	OFF	OFF	Stop charging and Discharging









4. Installation

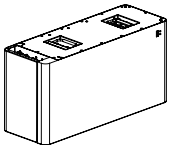

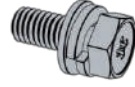







4.1 Tools





Tools			
Installation	Rubber mallet 	Star screwdriver 	Hammer drill (10 mm) 
	ESD gloves 	Safety goggles 	Anti-dust respirator 
	Safety shoes 	Level 	

4.2 Checking deliverables

After unpacking the battery, check whether deliverables are intact and complete.

Packing list of Battery Box				
No.	Part name/size	Quantity	Picture	Used for
1	Battery box	1		Battery box
2	Fixing plate between stacks	1		To fix the stacks
3	Crossed external hexagonal triple combination screws	4		To lock the fixing plate
4	Flat locating pin	4		To position multiple packs
5	Negative charging cable	1		Power cable -
6	Positive charging cable	1		Power cable +
7	Communication cable	1		For PACK communication
8	2g moisture-proof desiccant	2		Moisture-proof

System box packing list				
No.	Part name/size	Quantity	Picture	Used for
1	Support frame	1		To fix the battery on the wall
2	The base	1		To put at the bottom of the battery
3	Foot	4		To put at the bottom of the battery
4	L type plate	1		L shaped wall mount
5	The top	1		Install at the top of the battery
6	Rubber plug	4		Waterproof plug rod for top covert
7	Expansion screw	2		To fix the support frame
8	Cross screw with outer hegagon	2		Ground screw
9	Cross screw	4		To fix the top
10	Cross screw with outer hegagon	4		Lock base L parallel machine fixing plate
11	Cross screw with outer hegagon	3		The L-shaped wall mount box is fixed

12	Flat locating pin	4		Used for positioning multiple packs
13	Grounding cable	1		Used for the grounding
14	Negative charging cable	1		Battery negative power
15	Positive charging cable	1		Battery positive power
16	communication cable	1		For PACK communication

4.3 Installation

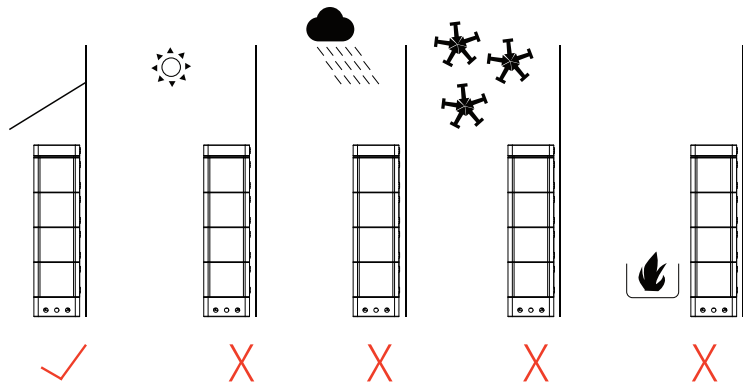

Step 1

Place the base against the wall, the distance between the base and the wall is 30mm as followed.

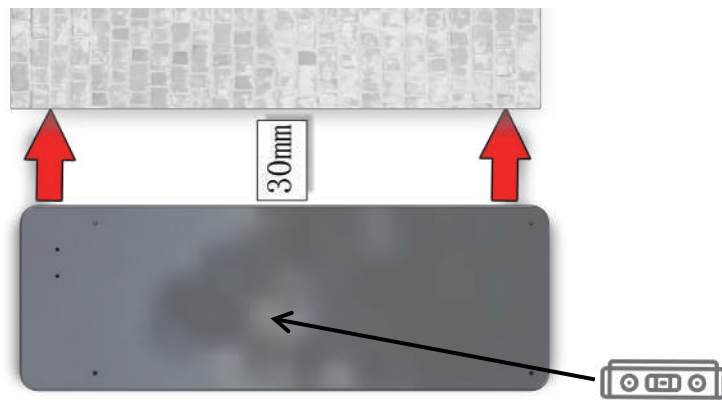

Note: Levelness of the base is less than 2mm.

Step 2

Screw the locating pin into the base and put the first battery pack on the base.

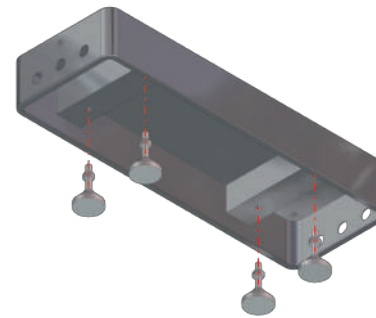

(2.1)

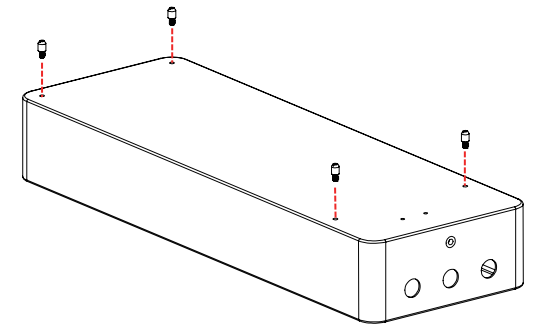

(2.2)

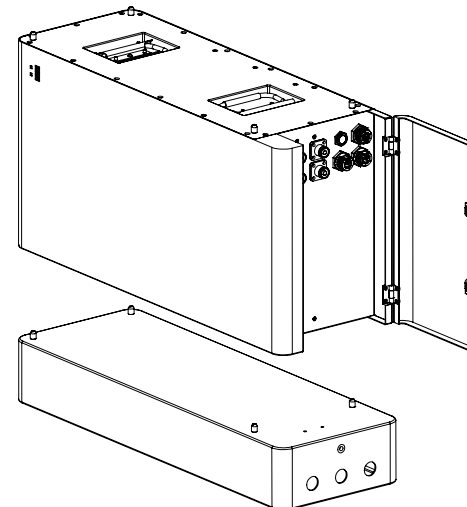

(2.3)

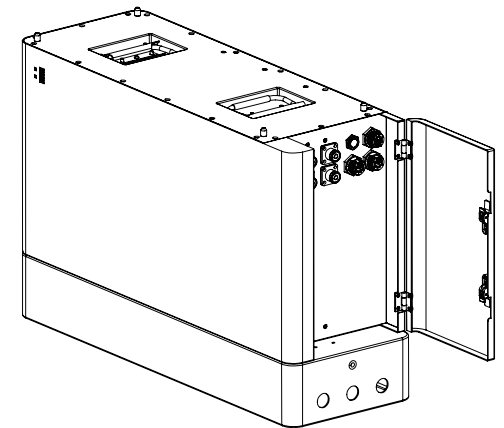

(2.4)

Step 3

Secure the battery module to the base with the L-shape plate.

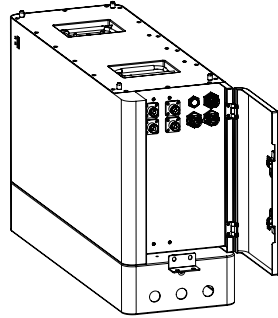

(3.1)

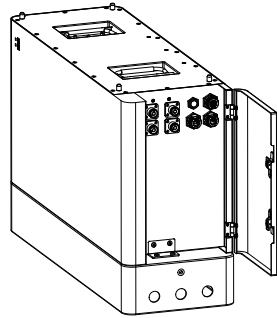

(3.2)

Step 4

Place the next battery module on top of the first battery module and secure the battery modules with the fixing plate. Repeat this step until all battery modules have been installed.

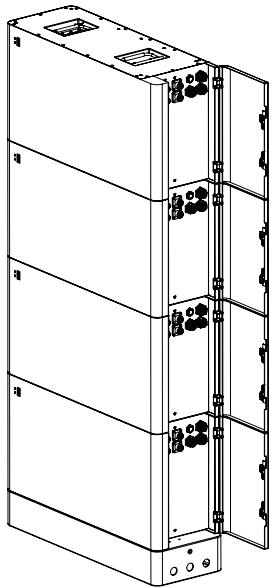

(4.1)

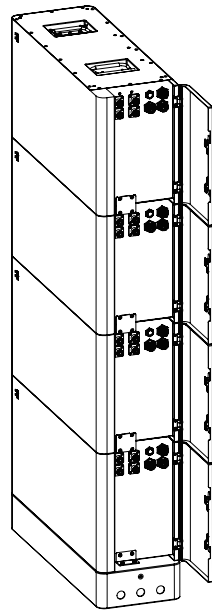

(4.2)

Step 5

Attached the L-shape support frame onto the battery as shown in the image.

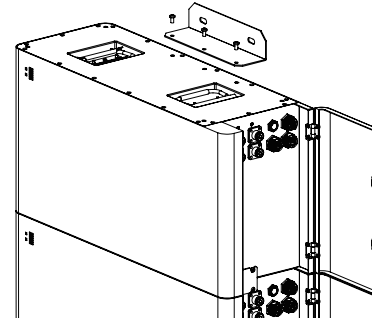

(5.1)

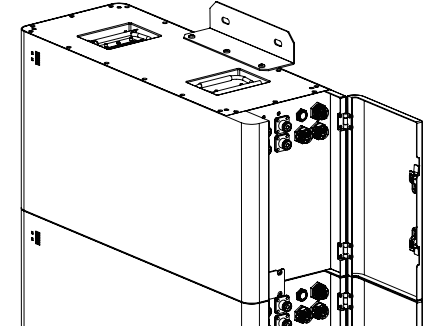

(5.2)

Step 6

Drill three holes of in the wall and insert three screw plugs. Insert three screws to secure the L-shape support frame to the wall.

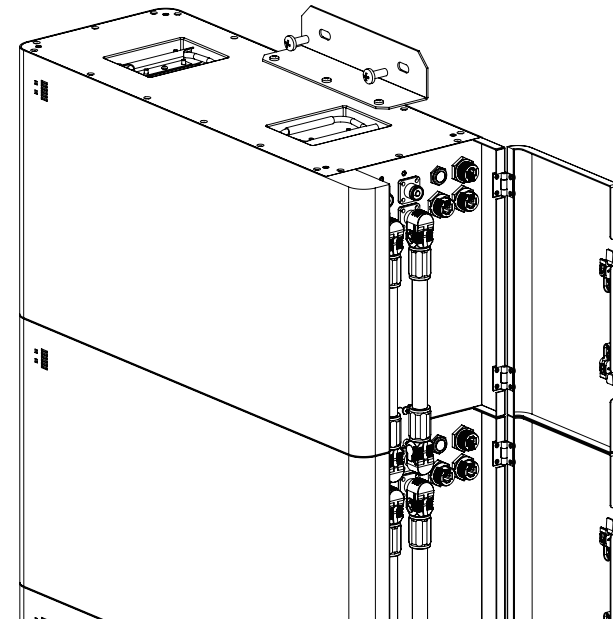

Step 7

Secure the top of the battery with the provided screws.

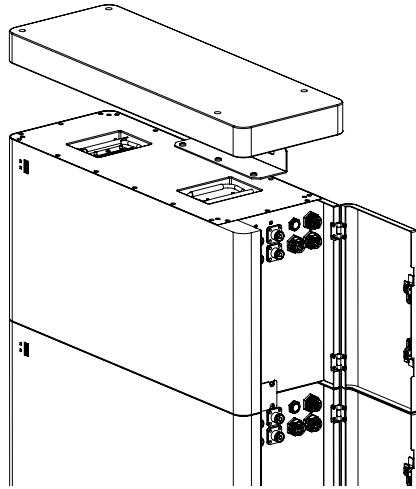

(7.1)

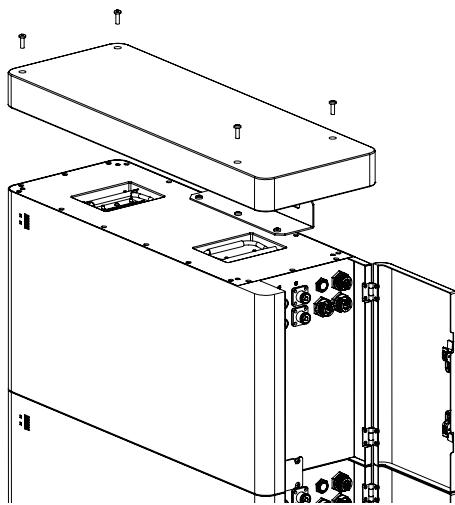

(7.2)

Step 8

Connect the small fixing plate between each modules as follows.

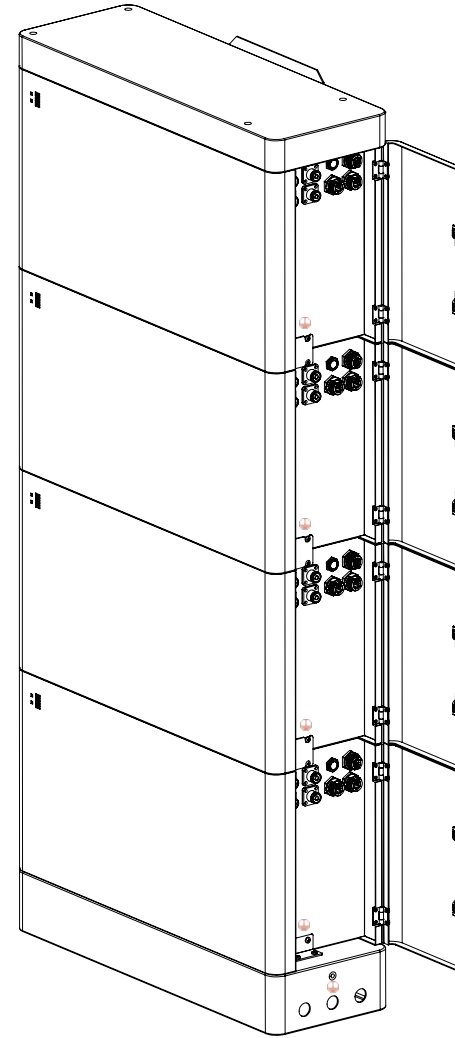

Step 9

Connect the power cables between the battery and the battery as shown.

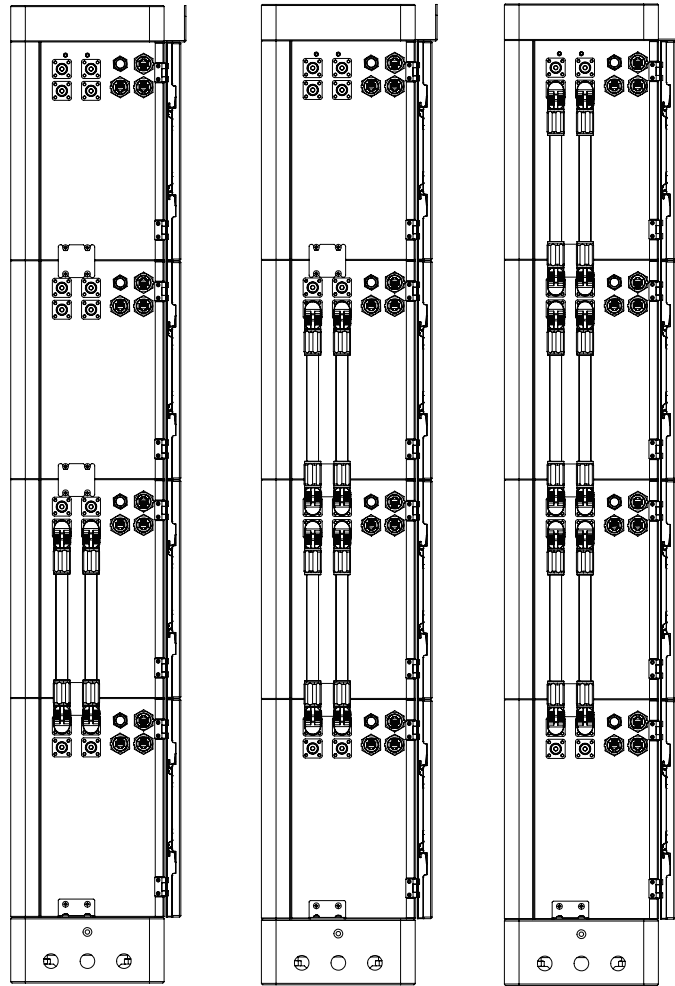

(9.1)

(9.2)

(9.3)

Connect the power through P+ and P- .

Connect the first battery pack COM Terminal to the inverter BMS port for communication between inverter and battery.

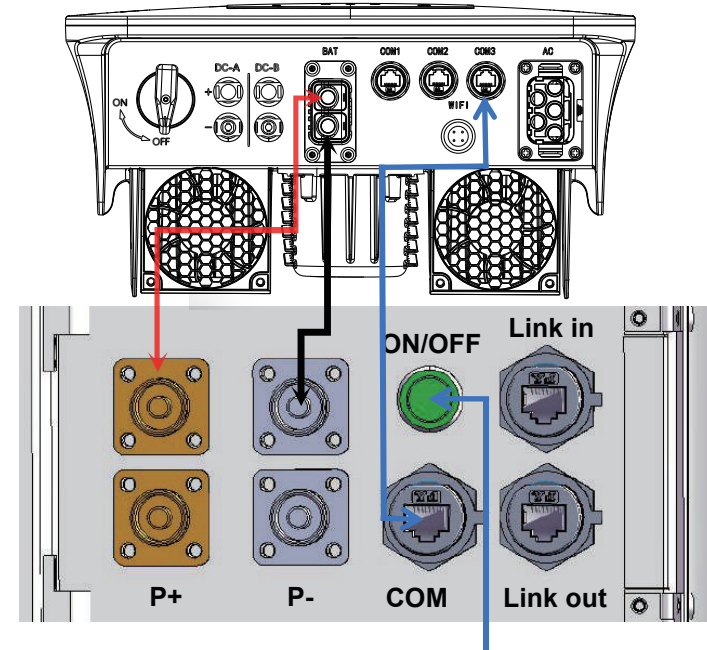

Choose one of the Link Com ports, the function is the same

After the harness is linked, press the button for 3S to turn on the batteries, 3S to turn off it.

 Danger	<p>Ensure power cables are installed with the correct polarity. A dangerous situation may arise if the polarities are reversed.</p>
 Danger	<p>Do not create a short circuit between the positive and negative terminals of the battery. Ensure the polarity is correct during installation.</p>
 Warning	<p>Incorrect communication cable connection will cause the battery system to operate in unexpected ways which may lead to system failure.</p>

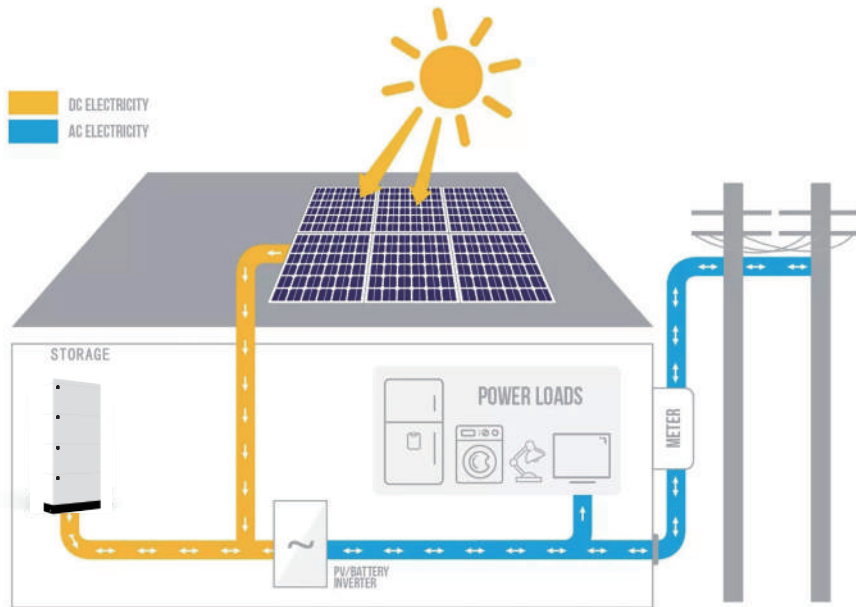

5. Commissioning Procedure

After all the cable (power and communication) connections are completed, please ensure the following:

- Ensure the DC switch on the inverter is OFF
- Ensure the AC switch that is connected to the grid and EPS output (if used) of the inverter is OFF
- Ensure the DC switch is OFF

For commissioning we recommend the following steps:

- Turn the DC switch ON
- Refer to section 3.3.2 Start for turning on the battery
- Wait until the LED's on
- Wait until the inverter LED's on
- Turn on the DC switch on the inverter
- Set up the battery and the inverter on the App
- Turn on the AC switch that is connected to the grid and EPS output of the inverter

6. Maintenance

● Recharge Requirements During Normal Storage

Battery should be stored in an environment with temperature range between $-10^{\circ}\text{C} \sim +45^{\circ}\text{C}$ and maintained regularly according to following table with 0.5C(50A) current till 50% SOC after long storage time.

Storage Environment Temperature	Relative Humidity of Storage Environment	Storage Time	SOC
Below -10°C	/	Prohibit	/
$-10\sim 25^{\circ}\text{C}$	5%~70%	≤ 12 months	SOC $\geq 60\%$
$25\sim 35^{\circ}\text{C}$	5%~70%	≤ 6 months	SOC $\geq 60\%$
$35\sim 45^{\circ}\text{C}$	5%~70%	≤ 3 months	SOC $\geq 60\%$
Above 45°C	/	Prohibit	/

● Recharge Requirements When Over Discharged

Over discharged (90%DOD) battery should be recharged according to following table, otherwise over discharged battery will be damaged.

Storage Environment Temperature	Storage Time	Note
$-10\sim 25^{\circ}\text{C}$	≤ 15 days	Battery Pack disconnected to inverter
$25\sim 35^{\circ}\text{C}$	≤ 7 days	
$35\sim 45^{\circ}\text{C}$	<12 hours	Battery Pack connected to inverter